

Main Ideas, Key Points, Questions:

After watching the video segment, write down key points, main ideas, and big questions.

Objective(s):

- *See examples of, and construct, a series electrical circuit.*
- *Understand how voltage and current behave in a series circuit.*

Notes:

During the video segment, use words, phrases, or drawings to take notes.



Summary:

After watching the video segment, write at least three sentences explaining what you learned. You may ask yourself: "If I was going to explain this to someone else, what would I say?"

Answer the following.

1. Which of the following circuits are series circuits? Circle all that apply.

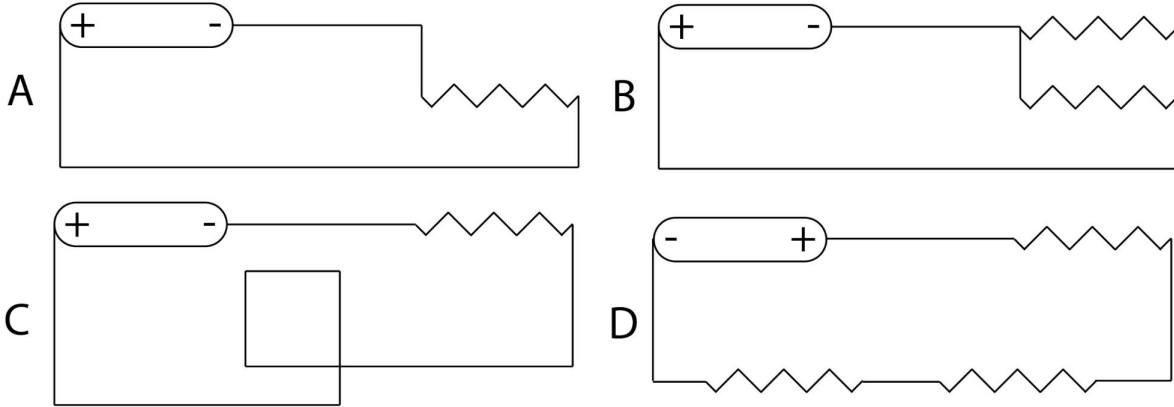

2. Is current the same all throughout a series circuit? Why or why not?

3. Is voltage the same all throughout a series circuit? Why or why not?

4. Image you have a battery, 5 identical light bulbs, and some wire. You wire up a series circuit with one of the light bulbs, then one by one add in each of the remaining four bulbs. If the current in the circuit with one bulb is I , write (in terms of I) the current in the circuit as each additional bulb is added. If R is the resistance of each bulb, write what the total circuit resistance is (in terms of R) as each bulb is added:

Number of Light bulbs in Circuit	Total Circuit Current	Total Circuit Resistance
1	I	R
2		
3		
4		
5		

Answer the following.

5. For the following series circuit, at each black dot along the circuit write how much voltage remains. Assume that 1) the resistors are all the same, and 2) the wires do not use up any voltage.

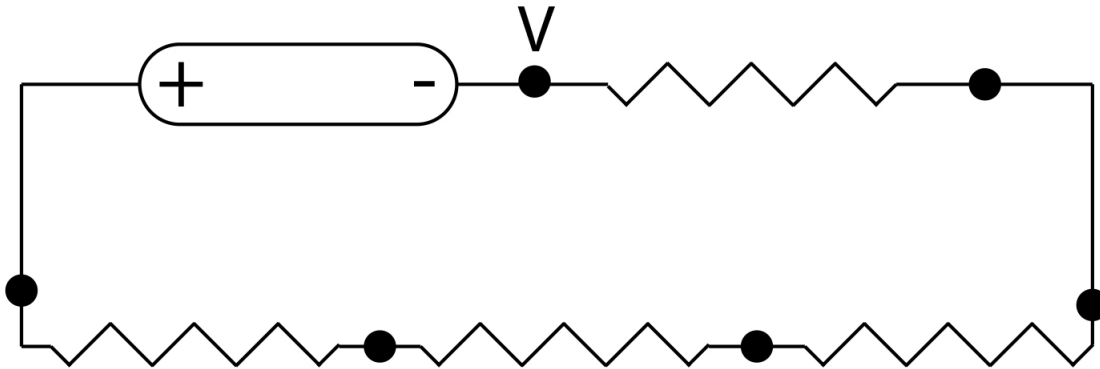

6. As the number of resistors in a series circuit increases, the overall resistance (circle one): *Increases, Decreases, Remains the same*. The current in the circuit (circle one): *Increases, Decreases, Remains the same*.
7. Three identical light bulbs are connected in series. Which of the following statements are true (circle all that apply):
- The total circuit resistance equals the sum of the individual resistors.
 - The current decreases the same amount as it passes through each bulb.
 - The voltage drop across each bulb is the same.
 - The first bulb shines more brightly than the last one.
8. Mathematically, in a series circuit, how do you find the total resistance of the circuit as it relates to the other resistors? What about the total current? Total voltage?